



Impinger® Low Profile Digital Advantage Series Single Belt Conveyorized Electric Oven

Models:

- 1622-000-A 1623-000-A 1624-000-A



Standard Features:

- AIR IMPINGEMENT uses hot air under pressure which surrounds food with small jets of hot air. This allows for rapid heating, cooking, baking and crisping of foods, two to four times faster than conventional ovens, depending on food product cooked.
- Uniform heating/cooking of food products offers a wide tolerance for rapid baking at a variety of temperatures.
- Continuous Cook Platform moves products through the oven one after another, improving product flow during cooking and virtually eliminating labor.
- Safety of conveyorized product movement is a definite advantage over batch type ovens, as it eliminates the need for constant tending.
- Oven has two self-contained heating systems.
- Customer specific air fingers on top and bottom allow for the heat to be adjusted and controlled by zoning.

Specifications:

General: Electric Baking/Finishing Oven is self-contained, conveyorized and stackable up to 3 high. Temperature is adjustable from 250°F (121°C) to 600°F (316°). Conveyor speed is adjustable from 1 minute to 30 minutes cooking time. Front door has access opening with see-through window to allow product to be placed on the moving conveyor inside the baking chamber when a shorter cook cycle is desired. The conveyor is removable through the right side opening and air distribution fingers are removable through the front door for easy cleaning. Crumb pans are located below the conveyor belt outside the baking chamber.

Digital Controls: The 4-button digital microprocessor control panel is located at the back right of the oven and has power on-off switch, temperature controls, and conveyor speed control. The VF readout displays actual cavity temperature in degrees (F° or C°), conveyor belt speed, thermostat indicator light, and diagnostic messages

for easy troubleshooting. All settings are automatically locked out to eliminate accidental changes to desired settings. All ovens are digitally calibrated at the factory, reducing the need for periodic calibration.

Construction: Exterior is fabricated from No.4 finish stainless steel. The air distribution system consists of two fans powered by 1/6 hp, AC Motors. The heated air is forced through eight (8) distribution fingers located in the baking chamber with four (4) above the conveyor belt and four (4) below. Each finger has required number of holes to create the air impingement effect on the food product passing through the baking chamber on the conveyor belt. The conveyor belt is a flexible stainless steel design with capacity for 32" (813mm) wide product and a travel distance of 72" (1829mm), of which 35 3/4" (908mm) is in the baking chamber. The indirect drive conveyor is powered by an AC motor with an external reversing switch on the rear of the motor control box for installations requiring opposite belt travel.



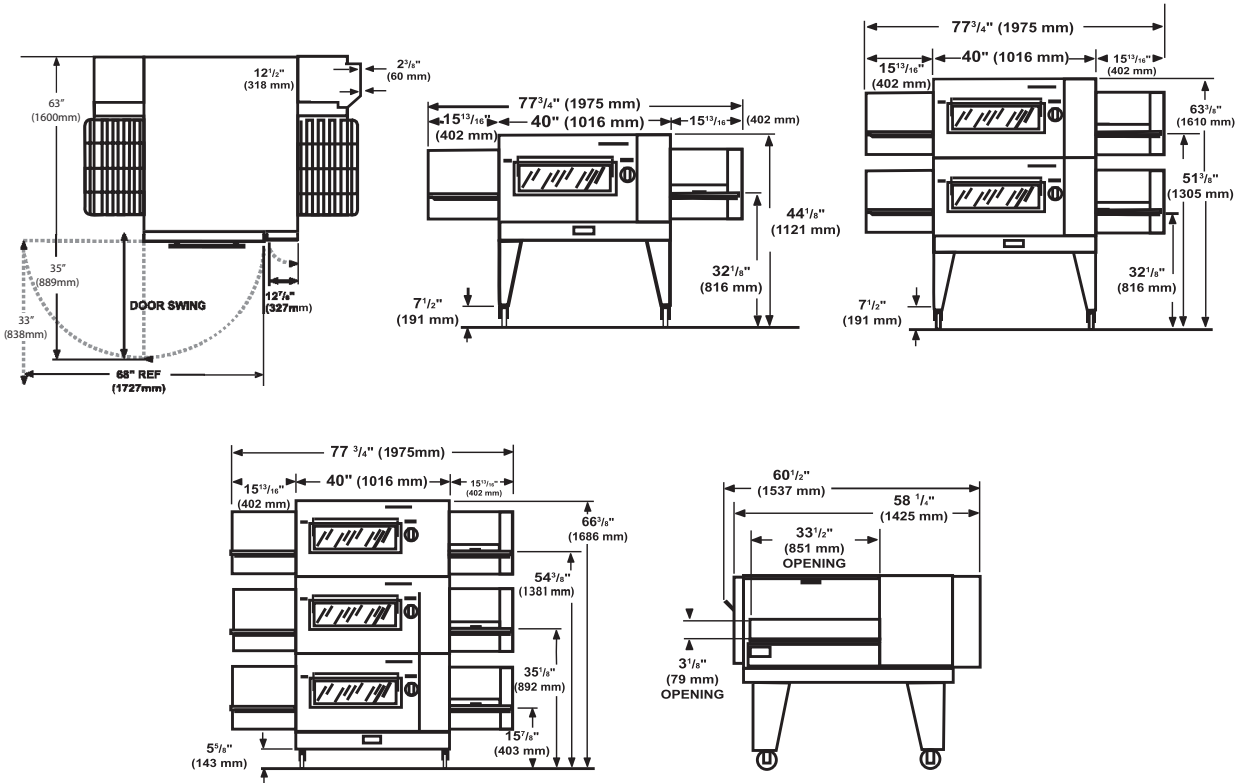

ELECTRICAL SERVICE: Each oven deck requires voltage, phase and hertz as indicated by model no. Neutral must be grounded at Electrical Service and receptacle properly polarized. All other models have terminal block connections. It is recommended that a separate 20 amp - 3 pole circuit breaker be provided for each oven deck.

VENTILATION: Ventilation is required. Local codes prevail. These are the "authority having jurisdiction" as stated by the National Fire Protection Association, Inc. in NFPA 96-1994. Consult the appropriate Installation and Operations manual for ventilation recommendations. The ventilation hood must operate in harmony with the building HVAC system. It typically requires between 2500 and 6000 CFM exhaust. Make-up air must be supplied by either a hood design or the HVAC system. In all cases, the ambient temperature around the oven must not exceed 95°F (35°C) when the oven is operating.

SPACING: The oven must have 6" (152mm) of clearance from combustible surfaces and 24" (610mm) clearance on both sides from other cooking equipment. A permanently installed oven requires approximately 11ft. (3553mm) of clearance overall to allow for removal of the conveyor and protective guards for cleaning. The conveyor is removed from the control side of the oven.

WARRANTY: All ovens installed in the United States or Canada come with a one (1) year parts and labor warranty starting from the date of "START-UP/CHECK-OUT".

Testing Agency Listing	Catalog No.	Width	Depth	Height Single Stack	Height Double Stack	Height Triple Stack	Input Rate	Volts	Amps	Phase	Hz
NSF/CSA	1622-000-A	60 1/2" (1537mm)	63" (1544mm)	44 1/8" (1121mm)	63 3/8" (1610mm)	66 3/8" (1121mm)	29 kW	208	81	3	60
NSF/CSA	1623-000-A	60 1/2" (1537mm)	63" (1544mm)	44 1/8" (1121mm)	63 3/8" (1610mm)	66 3/8" (1121mm)	29 kW	240	70	3	60
NSF/CSA	1624-000-A	60 1/2" (1537mm)	63" (1544mm)	44 1/8" (1121mm)	63 3/8" (1610mm)	66 3/8" (1121mm)	29 kW	220	77	3	60

NOTE: Specifications subject to change without notification.