

# IMPINGER® I DIGITAL ADVANTAGE SERIES SINGLE BELT CONVEYORIZED ELECTRIC OVEN

MODEL 1452  
MODEL 1453

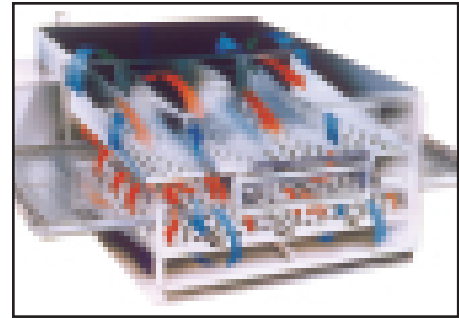

## FEATURES

- AIR IMPINGEMENT uses hot air under pressure which surrounds food with small jets of hot air. This allows for rapid heating, cooking, baking and crisping of foods, two to four times faster than conventional ovens, depending on food product cooked.
- Uniform heating/cooking of food products offers a wide tolerance for rapid baking at a variety of temperatures.
- Variable speed Continuous Cook Platform moves products through the oven one after another, improving product flow during cooking and virtually eliminating labor.
- Safety of conveyorized product movement is a definite advantage over batch type ovens, as it eliminates the need for constant tending.
- Oven has one self-contained heating system.
- Customer specific air fingers on top and bottom allow for the heat to be adjusted and controlled by zoning

## DIGITAL CONTROLS

The 4-button digital microprocessor control panel is located at the back right of the oven and has power on-off switch, temperature controls, and conveyor speed control. The LED readout displays actual cavity temperature in degrees (F° or C°), conveyor belt speed, thermostat indicator light, and diagnostic messages for easy troubleshooting. All settings are automatically locked out to eliminate accidental changes to desired settings. All ovens are digitally calibrated at the factory, reducing the need for periodic calibration.



## GENERAL

Electric Baking/Finishing Oven is self-contained, conveyorized and stackable up to 2 high. Temperature is adjustable from 250°F (121°C) to 600°F (316°). Conveyor speed is adjustable from 1 minute to 30 minutes cooking time. Front door has access opening with an optional see-through window to allow product to be placed on the moving conveyor inside the baking chamber when a shorter cook cycle is desired. Air distribution fingers are removable through the front door for easy cleaning. Crumb pans are located below the conveyor belt outside the baking chamber.

## CONSTRUCTION

Exterior is fabricated from No.4 finish stainless steel. The air distribution system consists of an axial type fan powered by 1/3 hp, AC Motor. The heated air is forced through eight (8) distribution Fingers located in the baking chamber with four (4) above the conveyor belt and four (4) below. Each finger has required number of holes to create the air impingement effect on the food product passing through the baking chamber on the conveyor belt. The conveyor belt is a flexible stainless steel design with capacity for 32" (813mm) wide product and a travel distance of 72" (1829mm), of which 35 3/4" (908mm) is in the baking chamber. The indirect drive conveyor system is powered by an AC motor with an external reversing switch on the rear of the motor control box for installations requiring opposite belt travel.

Item No. \_\_\_\_\_

# IMPINGER® | DIGITAL ADVANTAGE SERIES | MODEL 1452 SINGLE BELT CONVEYORIZED ELECTRIC OVEN | MODEL 1453

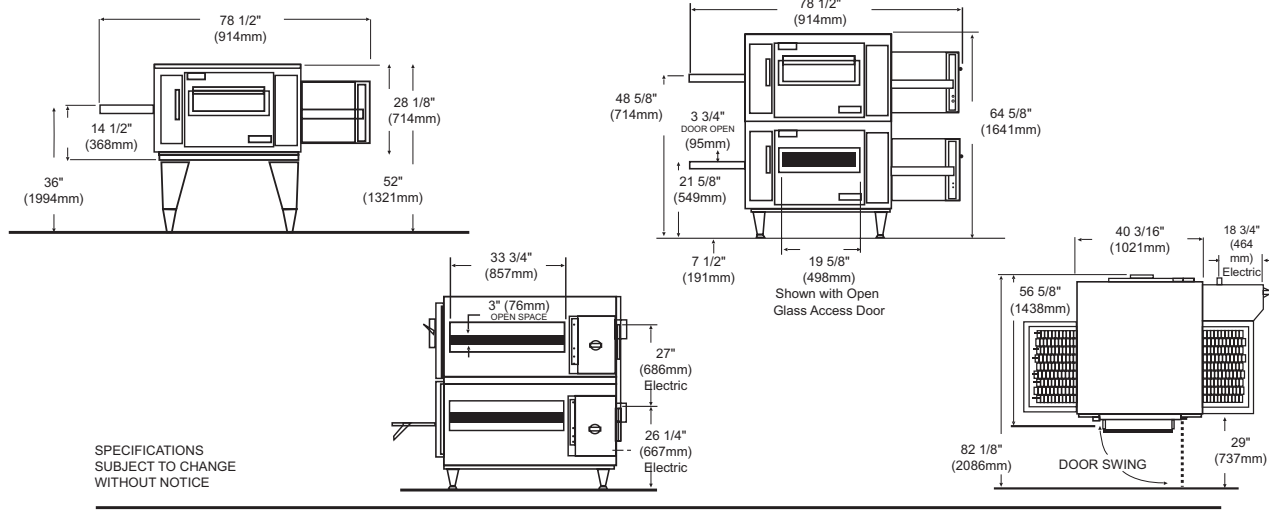

**ELECTRICAL SERVICE:** Heat is supplied by six (6) elements at 4500 watts each. Both ovens are rated at 27 kW. The 1452 is 208V, 80 amp, 3 phase, 60 Hz. The 1453 is 240V, 70 amp, 3 phase, 60 Hz. Each oven deck requires voltage, phase and hertz as indicated by model no. An independent earth ground is recommend.

**VENTILATION:** Ventilation is required. Local codes prevail. These are the "authority having jurisdiction" as stated by the National Fire Protection Association, Inc. in NFPA 96-1994. Consult Installation and Operations Manual for ventilation recommendations

**SPACING:** The oven must have 5" (127mm) of clearance from combustible surfaces and 24" (610mm) clearance on both sides from other cooking equipment. A permanently installed oven requires approximately 11ft. (3553mm) of clearance overall to allow for removal of the conveyor and protective guards for cleaning. The conveyor is removed from the control side of the oven.

**WARRANTY:** All new Impinger® ovens come with a one year parts/labor warranty. Defective parts of the original equipment on all installed ovens are warranted for one year from the date of "START-UP/CHECK-OUT".

| Testing Agency Listing | Cat. # | Width   | Depth   | Height Single Stack | Height Double Stack | Input Rate | Volts | Amps | Phase | Hz |
|------------------------|--------|---------|---------|---------------------|---------------------|------------|-------|------|-------|----|
| NSF/UL/ CSA            | 1452   | 78 1/2" | 56 5/8" | 52"                 | 64 5/8"             | 27 KW      | 208   | 80   | 3     | 60 |
| NSF/UL/ CSA            | 1453   | 78 1/2" | 56 5/8" | 52"                 | 64 5/8"             | 27 KW      | 240   | 70   | 3     | 60 |

Metric Dimensions for all Models: Width: 914mm; Depth: 1438mm; Height Single Stack: 1321mm; Height Double Stack: 1641mm.  
NOTE: If double stacked, each oven must be wired separately to carry rated load. U.S. Patent pending.

Note: following components - minimum requirements.

| Single:                | Double Stack:           |
|------------------------|-------------------------|
| 1 - Oven               | 2 - Ovens               |
| 1 - 1009 Top           | 1 - 1009 Top            |
| 1 - 1012 Stand         | 1 - 1010 Stand          |
| 8 - Columnating Panels | 16 - Columnating Panels |



1111 North Hadley Road, P.O. Box 1229  
Fort Wayne, Indiana 46801  
(219) 459-8200 • (800) 374-3004  
Fax: (219) 436-0735  
www.lincolnfp.com