



Model GXHP42

Standard Features:

- Heavy-duty removable drip pan
- 20,000 BTU/hr. per burner - natural gas
- 17,500 BTU/hr. per burner - propane gas
- Individual burner controls
- Standing pilot for instant lighting
- 3/4" (19mm) gas regulator
- 4" (102mm) legs with adjustable feet
- Stainless steel front, landing ledge, sides & valve cover

Specifications:

Shall be Garland Hot Plate, _____ BTU/Hour rating of when used with Model _____ with total _____ natural/propane gas. Finish is to be stainless steel front, sides, landing ledge and valve cover.

Optional features:

- Stainless steel stand with intermediate shelf
- Casters on stand- swivel type

Type of gas

- Natural
- Propane
- Elevation above 2,000 ft. (610m)
Specify ____ Ft. (m)



AVAILABLE MODELS:		TOTAL BTU	SHIPPING INFORMATION	
Model No.	Description	Natural/ Propane	Lbs/Kg	Cube Dimensions (LxDxH) In(mm)
GXHP11	1 Open Burner - 12"W x 16"D	20,000/17,500	50/23	30 (762) x 13 (330) x 16 (406)
GXHP21	2 Open Burners - 12"W x 28"D	40,000/35,000	73/33	30 (762) x 13 (330) x 16 (406)
GXHP22	2 Open Burners - 24"W x 16"D	40,000/35,000	81/37	30 (762) x 30 (762) x 16 (406)
GXHP33	3 Open Burners - 36"W x 16"D	60,000/52,500	123/56	42 (1067) x 40 (1016) x 26 (660)
GXHP42	4 Open Burners - 24"W x 28"D	80,000/70,000	135/61	30 (762) x 30 (762) x 16 (406)
GXHP63	6 Open Burners - 36"W x 28"D	120,000/105,000	191/87	42 (1067) x 40 (1016) x 26 (660)
GXHP84	8 Open Burners - 48"W x 28"D	160,000/140,000	247/112	54 (1372) x 40 (1016) x 26 (660)

Garland Commercial Industries, Inc.
185 East South Street
Freeland, Pennsylvania 18224
Phone: (570) 636-1000
Fax: (570) 636-3903

Garland Commercial Ranges Ltd
1177 Kamato Road, Mississauga, Ontario
L4W 1X4 CANADA
Phone: 905-624-0260
Fax: 905-624-5669

Enodis UK LTD
Swallowfield Way, Hayes, Middlesex
UB3 1DQ ENGLAND
Telephone: 081-561-0433
Fax: 081-848-0041

SPECIFICATIONS	SERIES						
	GXHP11	GXHP21	GXHP22	GXHP33	GXHP42	GXHP63	GXHP84
Width: In(mm)	12(305)	12(305)	24(610)	36(914)	24(610)	36(914)	48(1219)
Depth: In(mm)	16(406)	28(711)	16(406)	16(406)	28(711)	28(711)	28(711)
Height: In(mm)	10(254)	10(254)	10(254)	10(254)	10(254)	10(254)	10(254)
No. Burners	1	2	2	3	4	6	8
Total BTU-Nat.	20,000	40,000	40,000	60,000	80,000	120,000	160,000
Total BTU - Pro.	17,500	35,000	35,000	52,500	70,000	105,000	140,000
Gas Manifold	3/4" NPT	3/4" NPT	3/4" NPT	3/4" NPT	3/4" NPT	3/4" NPT	3/4" NPT
Operating Pressure	5" WC (12.5 Mbar) – Natural Gas						
	10" WC (25 Mbar) – Propane						

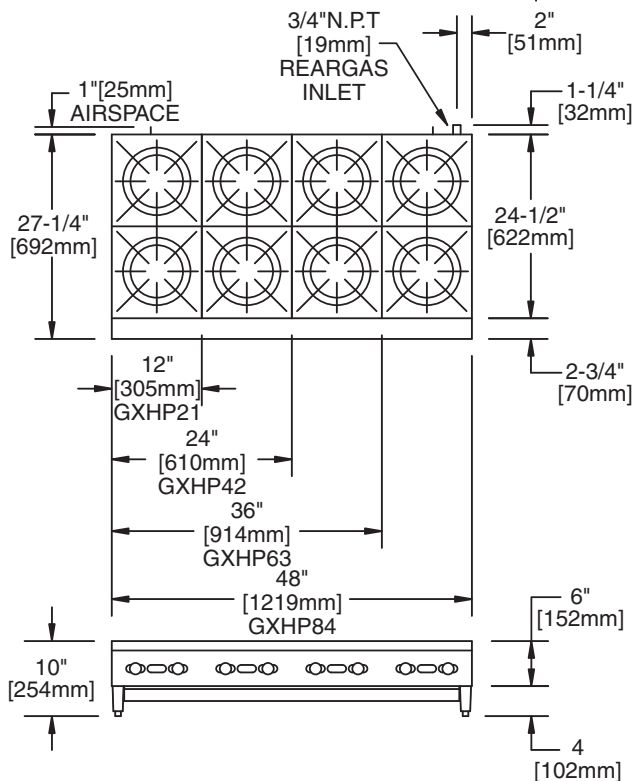
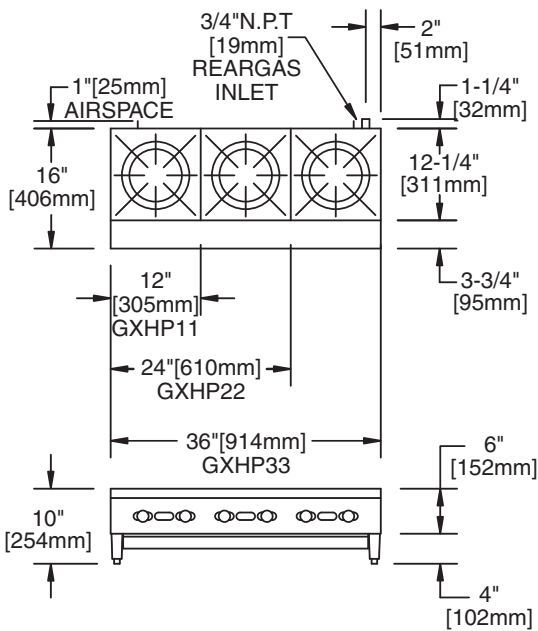
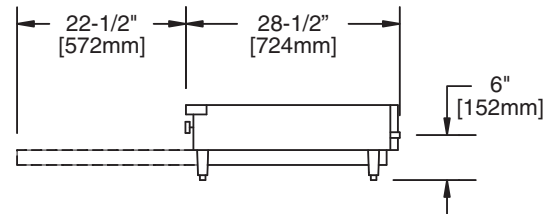
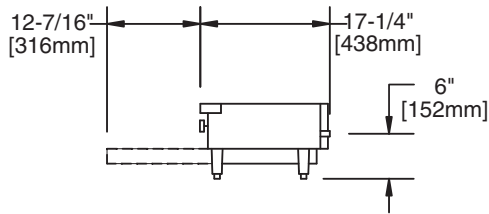

NOTE:

- Many local codes exist, and it is the responsibility of the Owner and the Installer to comply with those codes.
- Garland/U.S. Range products are not approved or authorized for home or residential use, but are intended for commercial applications only. Garland / U.S. Range will not provide service, warranty, maintenance or support of any kind other than in commercial applications.

Continuous product improvement is a Garland policy.