

SteamChef™ 3 & 6

High Speed Convection Steamer,

Automatic Water Fill & Drain, One 45,000 & One

62,000 BTU Gas Boiler-Free Counter Type Design



MODEL: (2) 22CGT63

Cleveland Standard Features

- Cooking capacity for up to three 12" x 20" x 2.5" deep steam table pans (1/1 G/N, 65 mm) for the upper compartment and six pans for the lower compartment.
- High-speed gas convection steamer with open style 1.5 gallon water reservoir located at the bottom of the cooking compartment for easy access and maintenance.
- Fan forced convection steam with patented **KleanShield™** cooking compartment design. **KleanShield™** collects and removes condensate waste from the cooking compartment. This keeps the compartment clean, safe from impurities and easy to maintain. Reduces foaming and avoids contamination of the reservoir water.
- Automatic water level controls, fills when main power switch is turned ON, Low Water and High Water probes inside cooking compartment maintains water levels during cooking, eliminating the need to manually refill and monitor water level during cooking. Large overflow port in rear wall. 193° preheat and standby temperature. High Temperature Safety Shut-off.
- Steam and Fan Shut Off Control when compartment door is opened.
- 45,000 BTU high efficiency atmospheric gas boilerless style heating system for the upper compartment and 62,000 BTU for the lower compartment.
- Front access works in a drawer style burners for easy servicing.
- Includes a 60-Minute Electro-Mechanical Timer, LED Indicator Lights for Power On and Reset. Timed and Manual Bypass Switch for constant steaming.
- Exclusive **SteamChef™** Automatic Drain Control. Compartment drains when main power is turned OFF via 1/2" ball valve with micro switch circuitry. Simple 1" NPT drain connection required with water saving cold water condenser and 3 minute rinse feature.
- Left Hand Door Hinging: Compartment Doors hinged on the left, controls on the right.
- Exclusive, durable 14 gauge stainless steel compartment door and latch withstands abuse and heavy wear. Two piece compartment door with free floating inner door is self adjustable and prevents leaks. Reversible door gasket doubles the life of the gasket.
- Heavy-duty 4" (102mm) Skid Resistant Adjustable Legs with Flanged Feet.
- UL - Gas, UL - Sanitation (NSF Standards).



Short Form Specifications

Shall be a Cleveland **SteamChef™ 3 & 6**, model (2) 22CGT3/6, two stacked single compartment (45,000 BTU upper and 62,000 BTU lower) high efficiency atmospheric gas boilerless style heating system. Front access "works in a drawer" style burners for easy servicing. Standard 60-minute electro-mechanical timers. Capacity for three 2.5" (1/1 G/N, 65 mm) full size steam table pans for the upper compartment and six pans for the lower compartment. Includes 1/2" ball valve style automatic drains. Automatic water level controls. Heavy-duty 14 gauge stainless steel cooking compartment doors and latches. **KleanShield™** clean cavity protection. Requires field installation. Includes Stacking Stand, Gas Flue Exhaust Kit and Common Drain and Water Connection Manifold.

- Stacking combination requires field installation of the steamers, stand and flue. This combination includes the following items:
 - ES263044 Stacking Stand (PN 111467G)
 - Gas Flue Exhaust Kit
 - Common Drain and Water Connection Manifold

Options & Accessories

- 5 Foot (1524mm) FDA Approved National Hose Thread style water connection kit (garden hose thread), 2 required (NHT60)
- Single Point Water Connection (SPW)

SECT. B PAGE 15
0707

<i>Top compartment has capacity for:</i>	<i>Bottom compartment has capacity for:</i>
Three, 12" x 20" x 2 1/2" deep Cafeteria Pans	Six, 12" x 20" x 2 1/2" deep Cafeteria Pans.
or	or
Six, 12" x 20" x 1" deep Cafeteria Pans.	Twelve, 12" x 20" x 1" deep Cafeteria Pans.
or	or
Two, 12" x 20" x 4" deep Cafeteria Pans	Four, 12" x 20" x 4" deep Cafeteria Pans

OPERATING CLEARANCES

3" Left, 3" Right and 3" Rear.

SERVICE CLEARANCES

12" on control side. Contact factory for variances to clearances.

CONTROLS (per compartment)

60-minute electro mechanical timer with load compensating feature.
Three function control switch for Timed Cooking and Continuous Steaming.

APPROVALS

UL - Gas, UL - Sanitation (NSF Standards)

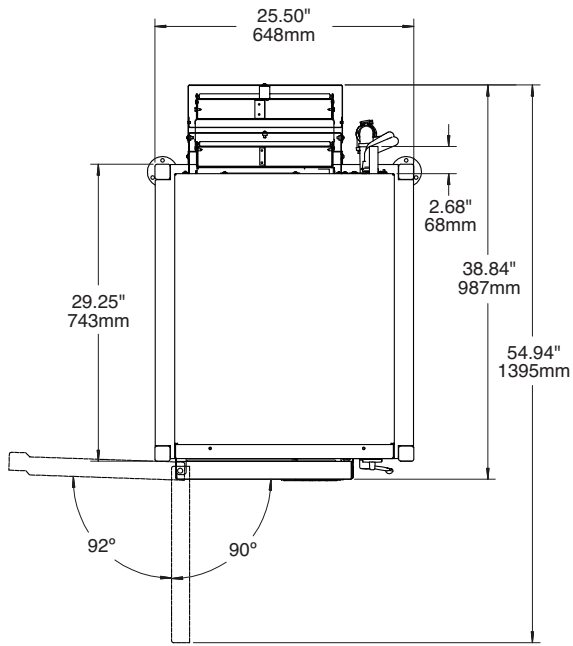

GAS (one connection per unit)

1/2" Dia. IPS
45,000 & 62,000 BTU's
SUPPLY PRESSURE: NATURAL - 4.00" W.C. minimum, 14.00" W.C. maximum
PROPANE - 12.00" W.C. minimum, 14.00" W.C. maximum
Manufacturer must be notified if unit will be used above 2,000 ft. altitude.

ELECTRICAL (one connection per unit)

115V, 1 Phase, 35 Watts.

COLD WATER

C1: Condensing Water Inlet, 35 Psi Minimum, 60 Psi Maximum.
C2: Fill Water Inlet, 35 Psi Minimum, 60 Psi Maximum.
Two 3/4" NH-F (Garden Thread) connections. Use NSF approved hose.

DRAIN CONNECTION

1" NPT-M
Do not connect other units to this drain.
Drain line must be vented. Vented drain connection included.
Do not connect drain to PVC pipe.

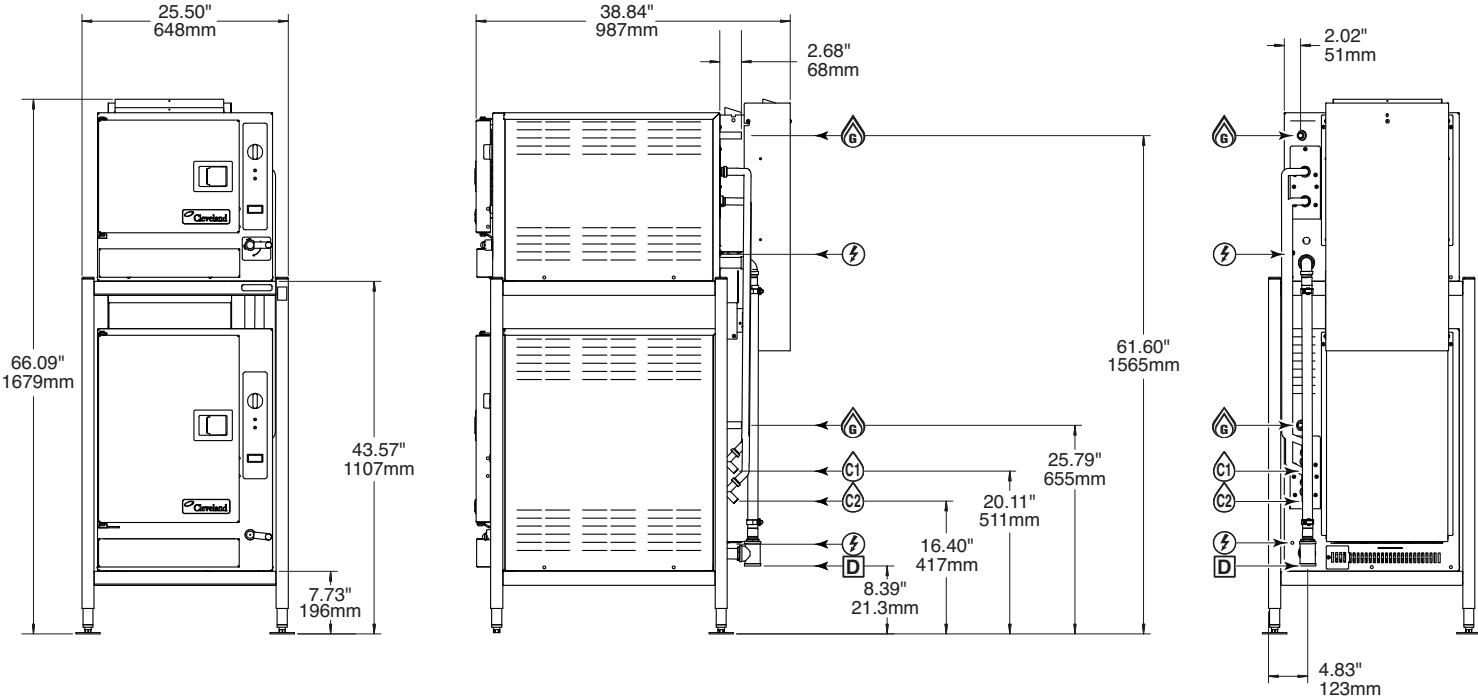

NOTES:

Cleveland Range reserves right of design improvement or modification, as warranted.
Many regional, state and local codes exist and it is the responsibility of the owner and installer to comply with the codes.
Cleveland Range equipment is built to comply with applicable standards for manufacturers. Included among those approval agencies are U.L./NSF#4 and CSA (AGA, CGA).