

SteamCraft® Ultra 5

COUNTER TYPE DESIGN

PRESSURELESS CONVECTION STEAMER

ELECTRIC STEAM GENERATOR, 16 KW

MODEL: 21-CET-16

Cleveland Standard Features

- Cooking Capacity for up to five 12" x 20" x 2½" deep Cafeteria Pans.
- **Innovative PowerPak Electric Steam Generator:** Two Special Stainless Steel Fire Bar Heating Element. Strong 14 Gauge Stainless Steel Construction. Large 5 gallon generator reservoir for faster steam cooking production. Fully insulated rear mounted steam generator.
- **Easy Access Cleaning Port:** Generator Cleaning Port located on the outside, top of the unit. Not necessary to remove hot panels or pan rack guides.
- **Generator Cleaning Light:** Indicator Light located on the front of the unit warns operator it is time to delime generator.
- **Instant Steam Stand By Mode:** Hold generator at a steaming temperature. Allows unit to start cooking instantly.
- **Durable 14 Gauge, Stainless Steel Construction:** For compartment door, cavity and steam generator.
- **One 60 Minute Electro-Mechanical Timer and Switch for manual operation:** Audible signal for cooking time completion.
- **Main Power On/Off Switch:** With Automatic Water Fill.
- **Exclusive Steam Cooking Distribution System:** Maintenance Free Exclusive Brass Steam Jets produce a high velocity convection steam without fans. Coved Corner design in cooking compartment distributes heat evenly, and is easy to keep clean. Creased top & bottom enhance drainage. Cold water condenser behind drain maintains a dry steam. Fully Insulated cooking compartment for thermal efficiency. Removable Stainless Steel Slide Racks for easy cleaning.
- **Automatic Generator Drain:** Contains a "Water Jet" Spray Rinse Drain Cleaning Cycle to keep drain clear.
- **Exclusive Automatic Remote Probe Type Water Level Control:** Separate from the generator for easy access.
- **Exclusive "Cool to the Touch" Two-Piece Compartment Door Design:** Free floating inner door with reversible gasket provides an air tight seal. Stainless Steel Slam/Latch Door Latch mechanism for reliability.
- **Left Hand Door Hinging:** Compartment Doors hinged on the left, controls on the right.
- Available in most voltages, three phase only.

Options & Accessories

- Right hand Door Hinging, Controls on the Left (DHR)



Shown with optional
Electronic Timer

Short Form Specifications

Shall be CLEVELAND, **SteamCraft® Ultra 5**, one compartment, Counter-Type Steamer, Model 21-CET-16, ___volts, 16.5 KW, ___Hz, 3 phase, heavy duty all Stainless Steel construction; rear mounted, insulated Steam Generator with Remote Probe Type Water Level Controls and Automatic Steam Generator Blowdown with "Water Jet" Drain Cleaning feature.

- Electronic Timer with Compensating Load Feature (ETC)
- ON/OFF Steam Switch for compartment controls (MC)
- 34" (864mm) High Stainless Steel Economy Stand, for one 21-CET-16 (UniStand34)
- POSK Pull-Out Shelf Kit for UniStand (P/N 111724)
- URK Pan Rack Kit UniStand (P/N 111726)
- 4" Stainless Steel Legs (LF4)
- Equipment Stacking Stand Shelf Type (ES2446)
- Dissolve® Descale Solution, 6 one gallon container w/quarter markings (106174)
- Compartment Door Steam Shut Off Switch (SCS)
- Cafeteria Pans in depths of 1", 2½" and 4"
- Water Filters

- Compartment has capacity for:
Five, 12" x 20" x 2½" deep Cafeteria Pans.

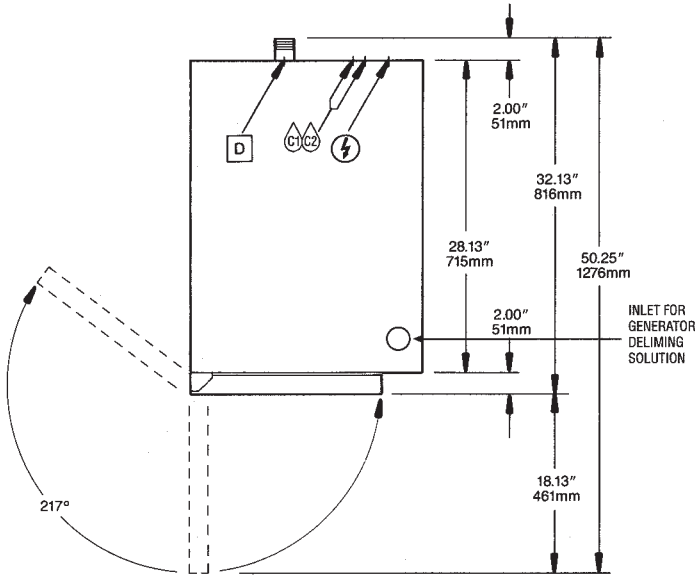

TOP VIEW

WATER QUALITY REQUIREMENT

The recommended minimum water quality standards whether untreated or pre-treated, based upon 10 hours of use per day, and a Daily Blowdown, are as follows:

TOTAL DISSOLVED SOLIDS	less than 60 parts per million
TOTAL ALKALINITY	less than 20 parts per million
SILICA	less than 13 parts per million
pH FACTOR	greater than 7.5
CHLORINE	less than 30 parts per million

Consult a local water treatment specialist for an on site water analysis for recommendations concerning steam generator feed water treatment (if required), in order to remove or reduce harmful concentrations of minerals. The use of highly mineralized water will mean that more frequent servicing of the steam generator will be necessary. The fact that a water supply is potable is not proof that it will be suitable for the generator.

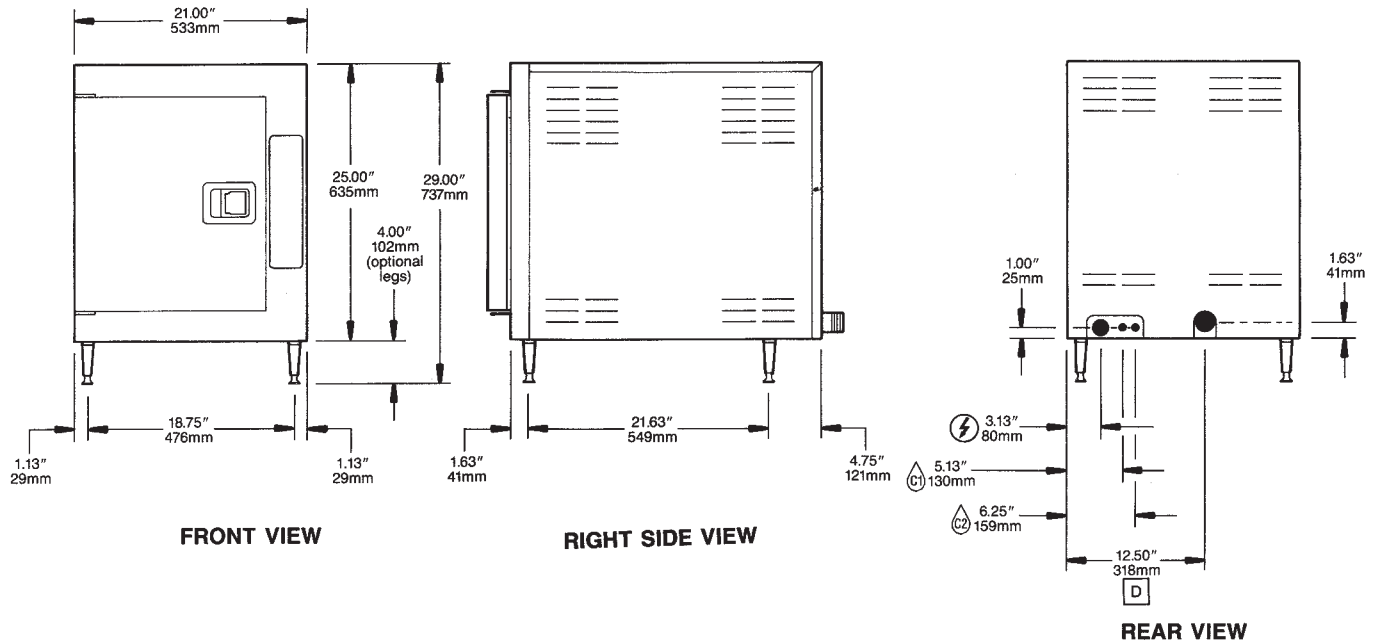

FRONT VIEW

RIGHT SIDE VIEW

REAR VIEW

ELECTRIC ⚡					WATER 💧	DRAINAGE 📦	CLEARANCE
Volts	Watts	Ph	Amps	Wire	Cold water: 35 psi minimum 60 psi maximum	1½" N.P.T. tube Do not connect other units to this drain.	Right - 3", Left - 3", Rear - 3" (12" on control side if adjoining wall or equipment is over 30" high for service access)
208	16,300	3	45.9	3			
220	13,694	3	36.5	3	Two ¼" NPT Tubing: C1 one for Condenser C2 one for Steam Generator	Drain line must be vented. No PVC pipe for drain.	Contact factory for variances to clearances.
240	16,300	3	39.8	3			
440	13,694	3	18.2	3	Unit comes with a 40 Mesh Water Strainer (installation required)		
480	16,300	3	19.9	3			
360	14,621	3	23.8	4			
380	16,300	3	25.1	4			
415	16,300	3	23.0	4			

NOTES:

Cleveland Range reserves right of design improvement or modification, as warranted.
Many regional, state and local codes exist and it is the responsibility of the owner and installer to comply with the codes.
Cleveland Range equipment is built to comply with applicable standards for manufacturers. Included among those approval agencies are UL, ULC, UL/NSF#4, CE and CSA.